

## TZ™-50

### Specifications

Model	TZ-50	
Measurements	Metric	US
Working height*	17.09 m	55 ft 6 in
Platform height	15.09 m	49 ft 6 in
Entry height	0.51 m	1 ft 8 in
Horizontal reach	8.89 m	29 ft 2 in
Clear outreach	7.04 m	23 ft 1 in
Up and over clearance	6.71 m	22 ft
▲ Platform length	0.68 m	2 ft 2.8 in
▲ Platform width	1.12 m	3 ft 8 in
▲ Height - stowed	2 m	6 ft 10 in
▲ Length - stowed	7.16 m	23 ft 6 in
▲ Width - stowed	1.68 m	5 ft 6 in
▲ Ground clearance - center	0.25 m	10 in
▲ Length - outrigger footprint	4.37 m	14 ft 4 in
▲ Width - outrigger footprint	4.37 m	14 ft 4 in

### Productivity

Lift capacity - standard	200 kg	440 lbs
Lift capacity - rotating platform	200 kg	440 lbs
Jib boom	1.25 m	4 ft 1 in
Jib working range	135°	135°
Self leveling platform	2.5° standard	
Platform rotation option	160° hydraulic	
AC power to platform	standard	
Turntable rotation	359° non-continuous	
Outrigger leveling capability	10°	
Drive speed	1.37 km/h	0.85 mph
Gradeability**	20%	
Towing speed rate	97 km/h	60 mph
Tongue weight - CE***	100 kg	220 lbs
Surge and parking brakes	standard	
Controls	variable speed system	
Tyre size	215 R14C	
Coupler	5.08 cm (2 in) hitch coupler standard	

### Power

Power source - standard	24V DC (four 6V 225 Ah batteries)
Power source - drive option	24V DC (four 6V 244 Ah batteries)
Power source - option	Hybrid DC/Gas Honda 4.1 kW (5.5 hp)
Fuel tank capacity	3.6 L / 0.95 gal
Hydraulic tank capacity	18 L / 4.75 gal
Hydraulic system capacity	30 L / 8.0 gal

### Sound & Vibration Levels

Sound pressure level (ground workstation)	<70 dBA	<70 dBA
Sound pressure level (platform workstation)	<70 dBA	<70 dBA
Vibration	<2.5 m/s <sup>2</sup>	<8 ft 2 in/s <sup>2</sup>

### Weight\*\*\*

Weight CE	2,025 kg	4,464 lbs
Unit weight modifiers for main options		
Platform rotation:	add 10 kg	add 23 lbs
Drive option:	add 105 kg	add 231 lbs
Bicycle guard:	add 15 kg	add 32 lbs
Full size spare tyre:	add 27 kg	add 60 lbs
Hybrid engine:	add 45 kg	add 100 lbs

### Standards Compliance

EU Directives: 2006/42/EC - Machinery (harmonized standard EN280:2013); 2004/108/EC (EMC); 2006/95/EC (LVD); 2000/14/EC (Outdoor Noise)

### Range Of Motion TZ-50

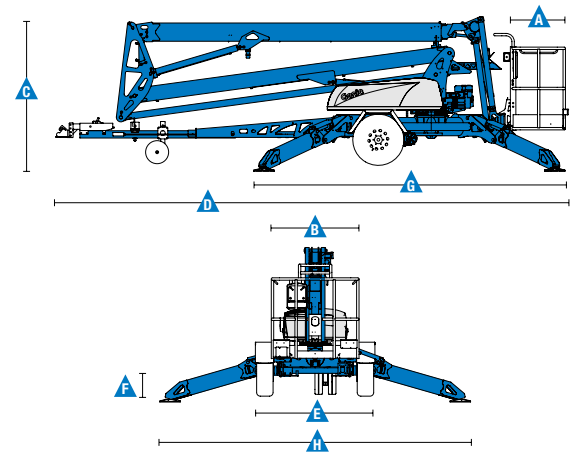
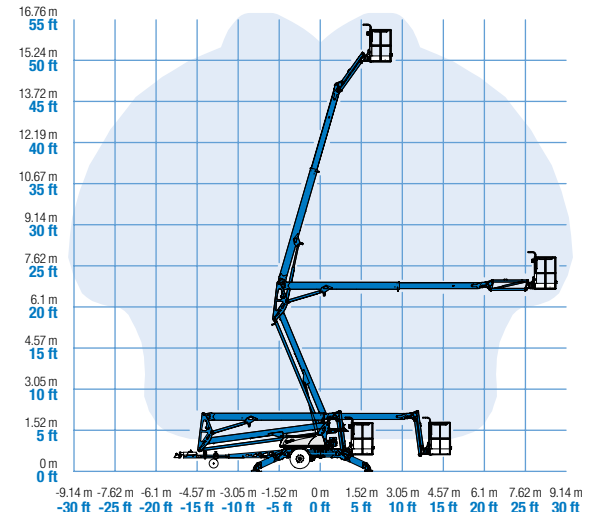

\* The metric equivalent of working height adds 2 m to platform height. U.S. adds 6 ft to platform height.

\*\* Gradeability applies to driving on slopes. See operator's manual for details regarding slope ratings.

\*\*\* Weight will vary depending on options and/or country standards.

### Features

#### Standard Features

##### Measurements

- 17.09 m (55 ft 6 in) working height
- 29 ft 2 in (8.89 m) horizontal reach
- Up to 227 kg (500 lbs ) lift capacity

##### Productivity

- Industry leading working envelope
- Extension boom
- Self-levelling platform
- 1.25 m (4 ft) jib with 135° working range
- AC wiring to platform
- Hydraulic outriggers
- Automatic 10° levelling system
- Outrigger interlocks
- Mechanical parking brake
- Hydraulic surge brakes
- Auxiliary pump down
- 5.08 cm (2 in) ball coupler
- Combination hitch with coupler lever lock
- Dual jockey wheels
- 359° non-continuous turntable rotation
- Easy to access batteries
- Hour meter
- Tilt alarm / sensor
- Forklift pockets
- Illuminated outrigger indicators
- Wheel chocks
- Spare tyre
- Battery charge indicator (BCI)
- Ladder
- Certified load sensor

##### Power

- 24V DC power source (four 6V 225 Ah batteries)

#### Easily Configured To Meet Your Needs

##### Platform Options

- Aluminum 0.68 x 1.12 m (26.8 x 44 in)
- 160° hydraulic platform rotation <sup>(1)</sup>

##### Power Options

- 24V DC power source
- Hybrid Honda 4.1 Kw (5.5 Hp) 45 amp charging system

##### Drive

- Drive option

##### Coupler

- 5.08 cm (2 in) ball coupler

##### Tyres

- 215 R14C tyres

#### Options & Accessories

##### Productivity

- Power to platform (incl. plug, socket and ground fault interrupt leakage on request)
- Track & Trace <sup>(2)</sup> (GPS unit providing machine location & operating information)
- Low temperature cut-out module
- Drive option with high capacity 244 Ah batteries pack
- Non-marking outrigger footpads
- Bicycle guard <sup>(3)</sup>
- Horn
- Flashing Beacon
- Fluorescent tube caddy
- Tool tray

##### Power

- Hybrid Honda 4.1 Kw (5.5 Hp) 45 amp charging system option



<sup>(1)</sup> Factory-fit option only

<sup>(2)</sup> Includes a first 2 years subscription

<sup>(3)</sup> Mandatory for France, Denmark, Netherlands



**CO.MA.CO S.r.l.**

via XIV Strada 21 - 20020 Cesate (MI) - Italy

Tel. +39 02 99065169

info@comacopro.com

[www.comacopro.com](http://www.comacopro.com)