

TZ™ -34/20

Specifications

Model	TZ-34/20	
Measurements	US	Metric
Working height*	40 ft	12.19 m
Platform height	34 ft	10.36 m
Entry height - extended	6.4 in	.16 m
Horizontal reach	18 ft 4 in	5.59 m
Clear out reach	13 ft 5 in	4.09 m
Up and over clearance	16 ft 1 in	4.90 m
A Platform length	2 ft 2.8 in	.68 m
B Platform width	3 ft 8 in	1.12 m
C Height - stowed	6 ft 4.5 in	1.94 m
D Length - stowed	18 ft .5 in	5.50 m
E Width - stowed	4 ft 9.1 in	1.45 m
F Ground clearance	9.5 in	.24 m
G Length - outrigger footprint	10 ft 8.4 in	3.26 m
H Width - outrigger footprint	11 ft 9.4 in	3.59 m

Productivity

Lift capacity (ANSI, CSA) - standard	500 lbs	227 kg
Lift capacity (ANSI, CSA) - rotating platform	460 lbs	209 kg
Lift capacity (CE/AUS) - standard	440 lbs	200 kg
Lift capacity (CE/AUS) - rotating platform	400 lbs	181 kg
Self leveling platform	standard	
Platform rotation option	90° mechanical	
AC power to platform	standard	
Turntable rotation	359° non-continuous	
Outrigger leveling capability	11°	
Towing speed rate	60 mph	97 km/h
Tongue weight - ANSI, CSA	315 lbs	143 kg
Tongue weight - CE	163 lbs	74 kg
Surge and parking brakes	standard	
Controls	variable speed system	
Tire size - ANSI, CSA	ST 205/75 R15	
Tire size - CE	185R-14C	
Coupler	combination hitch	

Power

Power source	24V DC (four 6V 225Ah batteries)	
Hydraulic tank capacity	2.65 gal	10 L
Hydraulic system capacity	4.5 gal	17 L

Weight**

ANSI, CSA, Australia	3,155 lbs	1,431 kg
CE	3,170 lbs	1,438 kg

Standards Compliance

ANSI A92.2, CSA C225, EN 280, AS 1418.10

* The metric equivalent of working height adds 2 m to platform height. U.S. adds 6 ft to platform height.
** Weight will vary depending on options and/or country standards.

Range Of Motion TZ-34/20

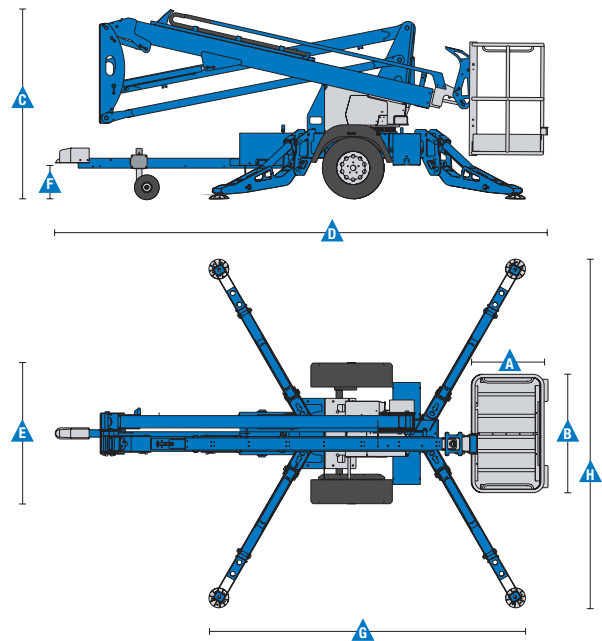
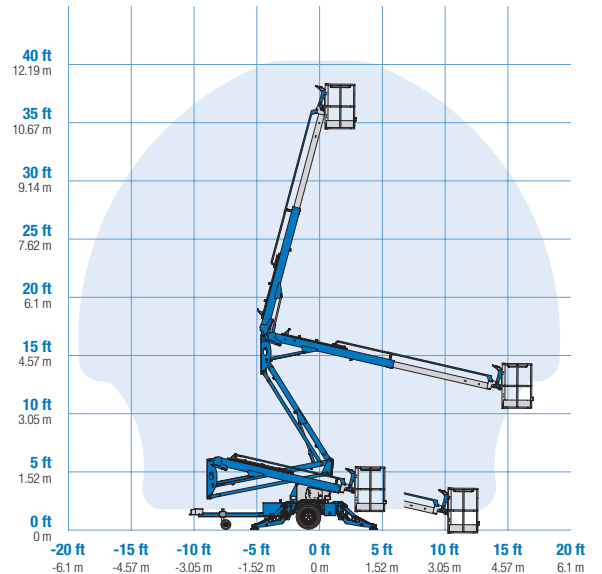

Features

Standard Features	Configurations	Options & Accessories
<p>Measurements</p> <ul style="list-style-type: none"> • 40 ft (12.36 m) working height • 18 ft 4 in (5.59 m) horizontal reach • Up to 500 lbs (227 kg) lift capacity <p>Productivity</p> <ul style="list-style-type: none"> • Industry leading working envelope • Extension boom • Self-leveling platform • Variable speed control system • AC wiring to platform • Hydraulic outriggers • Automatic 11° leveling system • Outrigger interlocks • Mechanical parking brake • Hydraulic surge brakes • 2 in (5.08 cm) coupler lever lock • Hitch pull bar • Adjustable hitch with coupler lever lock • Single jockey wheels • 359° non-continuous turntable rotation • Easy to access batteries • Hour meter • Tilt alarm / sensor • Forklift pockets • Illuminated outrigger indicators • Highway safety chains with snap hook • LED brake lights (ANSI, CSA) <p>Power</p> <ul style="list-style-type: none"> • 24V DC power source (four 6V 225 Ah batteries) 	<p>Platform Options</p> <ul style="list-style-type: none"> • Aluminum 26.8 x 44 in (.68 x 1.12 m) • 90° mechanical platform rotation <p>Power</p> <ul style="list-style-type: none"> • 24V DC power source <p>Coupler Options</p> <ul style="list-style-type: none"> • Adjustable hitch <ul style="list-style-type: none"> - 2 in (5.08 cm) ball coupler - 2 5/16 in (5.87 cm) ball coupler - 2 1/2 in (6.53 cm) I.D. pintle ring coupler - Clevis coupler <p>Tire Options</p> <ul style="list-style-type: none"> • ST 205/75 R15 tires (ANSI, CSA) • 185 R14C tires (CE) • Dual 10 in (25.4 cm) air filled tires 	<p>Productivity</p> <ul style="list-style-type: none"> • 90° mechanical platform rotation • Wheel chocks • Fluorescent tube caddy • Full size spare tire • Flashing beacon • Non-marking outrigger footpads • Battery charge indicator (BCI) • Tool tray • Horn



CO.MA.CO S.r.l.
via XIV Strada 21 - 20020 Cesate (MI) - Italy
Tel. +39 02 99065169
info@comacopro.com
www.comacopro.com